

APPLICAZIONI

Gruppi di pressurizzazione a funzionamento automatico realizzati con elettropompe jet autoadescanti.

Molto affidabili e silenziosi sono particolarmente adatti per aumentare la pressione disponibile da una rete di distribuzione, per l'approvvigionamento d'acqua con aspirazione da pozzi e per impianti idrici domestici.

APPLICATION

Automatic high pressure groups coupled with selfpriming jet pumps.

They are very silent and reliable and particularly suitable to increase pressure from a water system, to supply water from wells and in domestic high pressure groups.

LIMITI D'IMPIEGO

- Temperatura liquido fino a 35°C
- Temperatura ambiente fino a 40°C
- Altezza d'aspirazione manometrica fino a 8 mt.
- Pressostato pre-tarato 1,4÷2,8 bar
- Servizio continuo

MOTORE

- Motore elettrico ad induzione a 2 poli ($n = 2850 \text{ min}^{-1}$)
- Isolamento Classe F
- Protezione IP 44

COMPONENTI

- Serbatoio a membrana
- Tubo flessibile raccordato
- Pressostato con cavi pre-tarato
- Manometro
- Raccordo ottone

OPERATING CONDITIONS

- Liquid temperature up to 35°C
- Ambient temperature up to 40°C
- Total suction lift up to 8 mt.
- Adjusted switch on/off pressure 1,4÷2,8 bar
- Continuous duty

MOTOR

- Two-Pole induction motor ($n = 2850 \text{ min}^{-1}$)
- Insulation Class F
- Protection IP 44

COMPONENTS

- Membrane tank
- Flexible hose with connection
- Pre-set pressure switch with cable
- Pressure gauge
- Brass connection

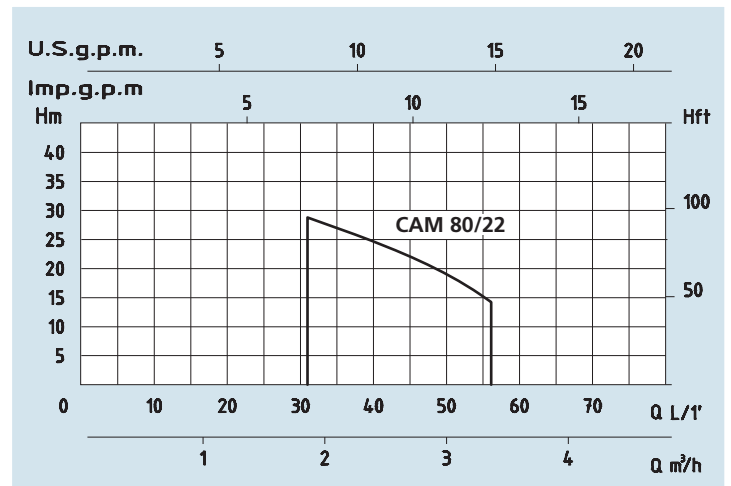
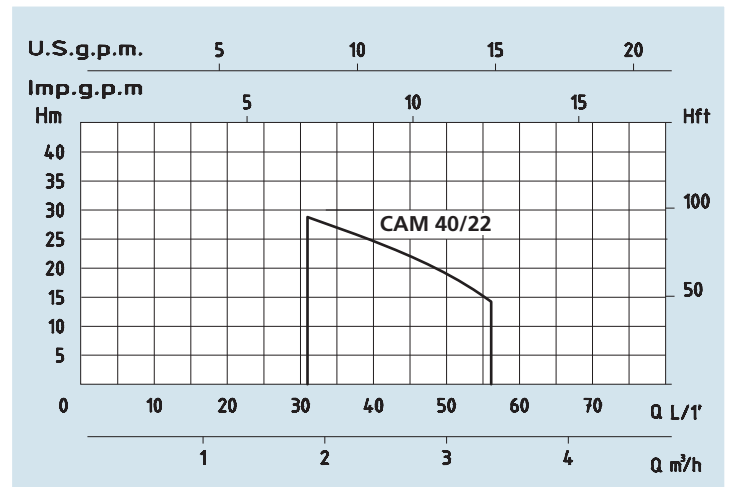

DATI TECNICI - TECHNICAL DATA

TIPO - TYPE	POTENZA NOMINALE NOMINAL POWER P2	POTENZA ASSORBITA INPUT POWER P1	AMPERE	Pressostato pre-tarato Adjusted switch on/off pressure	Q = PORTATA - CAPACITY											
					m ³ /h	0,6	0,9	1,2	1,5	1,8	2,1	2,4	2,7	3	3,6	
Monofase Single-phase	HP	kW	kW	1 x 230V	Bar	lt/1'	10	15	20	25	30	35	40	45	50	60
230V-50Hz						Prevalenza manometrica totale in m.C.A. - Total head in meters w.c.										
CAM 40/22	0,8	0,6	0,8	3,8	1,4 ÷ 2,8	H	38	36	34	32	29	27	25	22	19	
CAM 80/22	0,8	0,6	0,8	3,8	1,4 ÷ 2,8	(m)	38	36	34	32	29	27	25	22	19	



CAM 40-22



CAM 80-22

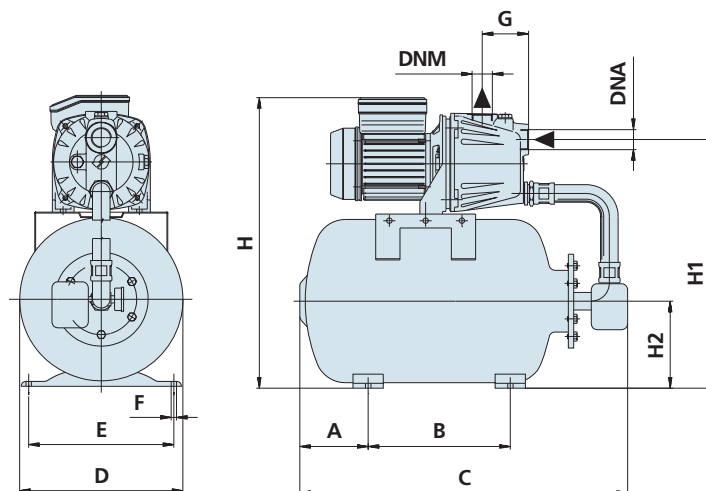

DIMENSIONI E PESI - DIMENSIONS AND WEIGHTS

TIPO - TYPE	DIMENSIONI mm - DIMENSIONS mm												DIMENSIONI DIMENSIONS mm 			Peso Weight Kg
	A	B	C	D	E	F	G	H	H1	H2	DNA	DNM	P	L	H	
Monofase Single-phase																
CAM 40/22	113	235	542	270	240	9	76	480	411	144	1"	1"	280	490	480	14
CAM 80/22	113	235	542	270	240	9	72	460	411	144	1"	1"	280	490	480	12