

APPLICAZIONI

Elettropompe sommerse multistadio per pozzi profondi da 6" (DN 150 mm).
Particolarmente adatte per applicazioni civili e industriali, alimentazioni getti d'acqua e fontane, impianti antincendio, l'irrigazione in generale e per l'approvvigionamento di acqua pulita.

APPLICATION

Multistage submersible water pumps for 6" deep wells (DN 150 mm).
Particularly suitable for civil and industrial purposes, for sprinkler and food irrigation plants, in fire intallations and generally speaking for clean water supplying.

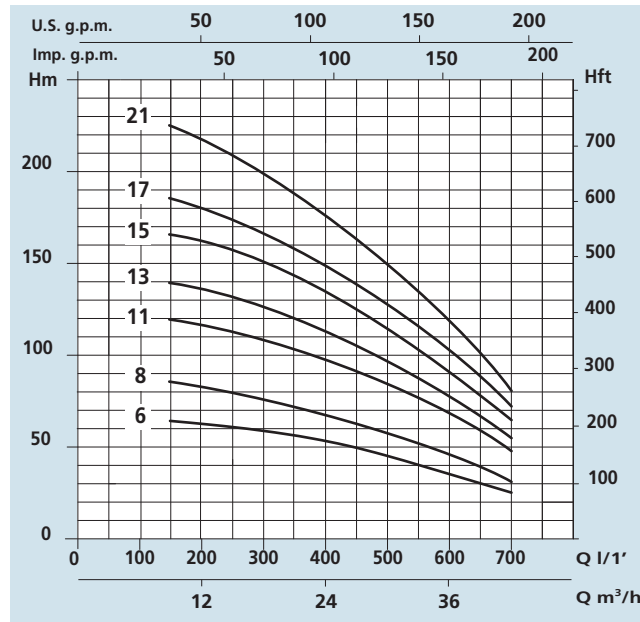

LIMITI D'IMPIEGO

- Temperatura liquido fino a 35°C
- Contenuto di sabbia max. 100 g/m³
- Partenza /ora 20 max.

OPERATING CONDITIONS

- Liquid temperature up to 35°C
- Sand content max. 100 g/m³
- Start/hour 20 max.

MOTORE

- Motore elettrico ad induzione a 2 poli (n=2850 min⁻¹)
- Motore sommerso in bagno d'olio
- Isolamento Classe F
- Protezione IP 68
- Servizio continuo

MOTOR

- Two-pole induction motor (n=2850 min⁻¹)
- Submersible motor in oil bath
- Class F Insulation
- IP 68 Protection
- Continuous duty

MATERIALI MOTORE

- Camicia esterna Acciaio inox
- Albero motore Acciaio inox

MOTOR MATERIALS

- External casing Stainless steel
- Motor shaft Stainless steel

MATERIALI POMPE

- Camicia esterna Acciaio inox
- Albero motore Acciaio inox
- Stadi e giranti Acciaio inox

PUMP MATERIALS

- External casing Stainless steel
- Motor shaft Stainless steel
- Stages and impellers Stainless steel

Tipo - Type	DIMENSIONI - DIMENSIONS mm		
	A	B	C
SXT 636-06	570	846	1416
SXT 636-08	600	1038	1638
SXT 636-11	600	1326	1926
SXT 636-13	700	1518	2218
SXT 636-15	700	1710	2410
SXT 636-17	760	1902	2662
SXT 636-21	830	2286	3116

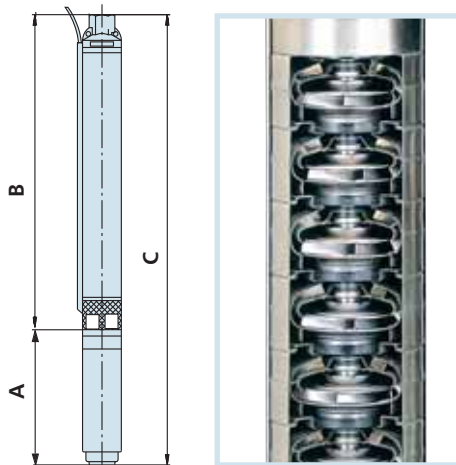

SXT 636

DATI TECNICI - TECHNICAL DATA

TIPO - TYPE	POTENZA NOMINALE NOMINAL POWER P2		Stadi Stages	Q = PORTATA - CAPACITY												DNM
	HP	kW		m³/h												
				9	12	15	18	21	24	27	30	33	36	39	42	
230/400V-50Hz				150	200	250	300	350	400	450	500	550	600	650	700	
SXT 636-06	7,5	5,5	6	64	62	60	58	56	52	49	45	40	36	30	25	3"
SXT 636-08	10	7,5	8	87	84	81	78	73	68	64	58	53	46	38	31	3"
SXT 636-11	12,5	9,3	11	120	117	112	108	102	97	90	83	76	67	57	47	3"
SXT 636-13	15	11	13	140	137	132	127	120	113	105	97	87	77	66	55	3"
SXT 636-15	17,5	13	15	166	162	157	150	142	134	124	113	102	90	77	65	3"
SXT 636-17	20	15	17	185	180	173	167	158	148	138	127	116	103	88	71	3"
SXT 636-21	25	18,5	21	226	220	212	202	190	177	164	149	134	117	100	80	3"