

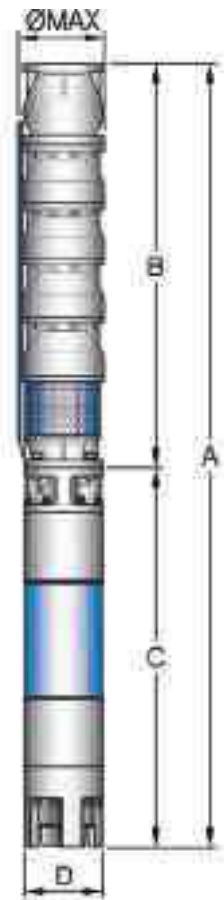

Tipo Type Type	Motore Motors 2900 g/m Moteurs		Q = Portata - Capacity - Débit											
			Cv Hp	Kw	l/sec	0	55,6	66,7	72,2	77,8	83,3	88,9	94,5	100
					l/min	0	3333	4000	4333	4667	5000	5333	5667	6000
					mc/h	0	200	240	260	280	300	320	340	360
FB12SG/1G + 8F30	30	22	43	28	25	24	22	19	17	14				
FB12SG/1F + 8F35	35	26	47	30	28	26	25	23	20	17	15			
FB12SG/1D + 8F40	40	30	49	33	30	29	27	25	23	20	17			
FB12SG/2N + 8F50	50	37	74	47	41	37	32	27	21	15				
FB12SG/2G + 8F60	60	45	87	57	51	48	44	39	34	28				
FB12SG/2F + 8F70	70	51	95	61	57	53	51	46	40	34	30			
FB12SG/2D + 8F75	75	55	100	66	61	58	55	51	46	41	35			
FB12SG/2A + 8F80	80	59	104	70	65	62	59	55	51	46	41			
FB12SG/3L + 8F85	85	62	124	80	71	65	58	51	43					
FB12SG/3G + 8F90	90	66	133	87	78	73	67	60	52	43				
FB12SG/3F + 10F100	100	75	145	94	87	82	76	70	63	54	45			
FB12SG/3A + 10F125	125	92	160	107	99	95	90	85	78	71	63			
FB12SG/4D + 10F150	150	110	204	134	124	118	112	104	94	84	72			
FB12SG/5F + 10F180*	180	132	243	156	143	136	125	116	104	89	73			
FB12SG/6G + 10F180*	180	132	268	174	157	147	134	120	104	87				
FB12SG/6F + 10F200*	200	150	291	187	174	164	152	140	126	108	90			
FB12SG/6D + 10F230*	230	170	306	202	186	177	168	156	142	126	108			
FB12SG/7D + 10F260*	260	190	357	235	217	207	196	182	165	147	126			



### Dimensioni e pesi

Overall dimensions and weights - Dimensions d'encombrement et poids

Tipo Type Type	Cv Hp	Kw	A (mm)	B (mm)	C (mm)	D (mm)	ø max (mm)	DN	Peso - Weight - Poids		
									A (kg)	B (kg)	C (kg)
									FB12SG/1G + 8F30	30	22
FB12SG/1F + 8F35	35	26	1930	881	1049	251	115	136			
FB12SG/1D + 8F40	40	30	1930	881	1049	253	115	138			
FB12SG/2N + 8F50	50	37	2180	1061	1119	295	142	153			
FB12SG/2G + 8F60	60	45	2290	1061	1229	313	142	171			
FB12SG/2F + 8F70	70	51	2290	1061	1229	314	142	172			
FB12SG/2D + 8F75	75	55	2410	1061	1349	326	142	184			
FB12SG/2A + 8F80	80	59	2410	1061	1349	326	142	184			
FB12SG/3L + 8F85	85	62	2590	1241	1349	353	169	184			
FB12SG/3G + 8F90	90	66	2660	1241	1419	374	169	205			
FB12SG/3F + 10F100	100	75	2679	1241	1438	240	290	175	479	174	305
FB12SG/3A + 10F125	125	92	2809	1241	1568				522	174	348
FB12SG/4D + 10F150	150	110	3129	1421	1708				595	201	394
FB12SG/5F + 10F180*	180	132	3409	1601	1808				649	228	421
FB12SG/6G + 10F180*	180	132	3589	1781	1808				676	255	421
FB12SG/6F + 10F200*	200	150	3709	1781	1928				705	255	450
FB12SG/6D + 10F230*	230	170	3809	1781	2028				745	255	490
FB12SG/7D + 10F260*	260	190	4089	1961	2128				812	282	530

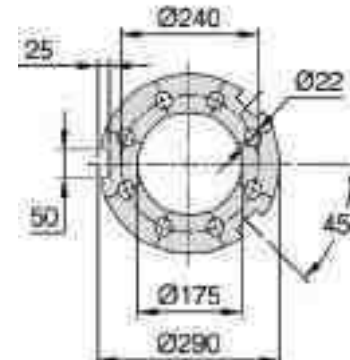

\* Non consigliata per montaggio in posizione orizzontale

\* This electropump isn't recommended for horizontal assemblage

\* Cette électropompe n'est pas recommandée pour le montage en position horizontale

# CURVE DELLE PRESTAZIONI

PERFORMANCES' CURVES  
COURBES DES PERFORMANCES

# FB12SG

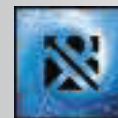

**n=2900 1/min 50 Hz**

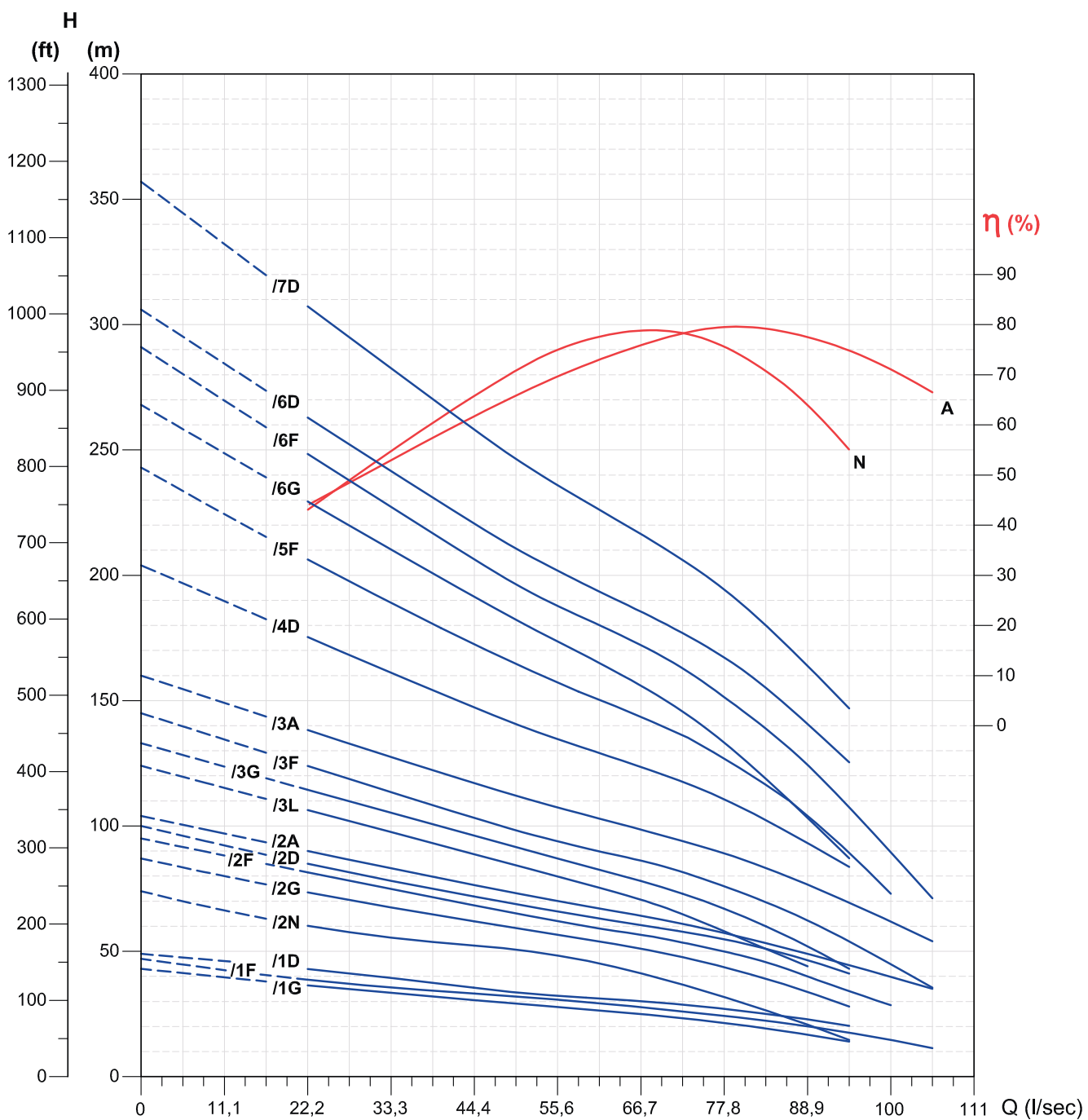

**NPSH**

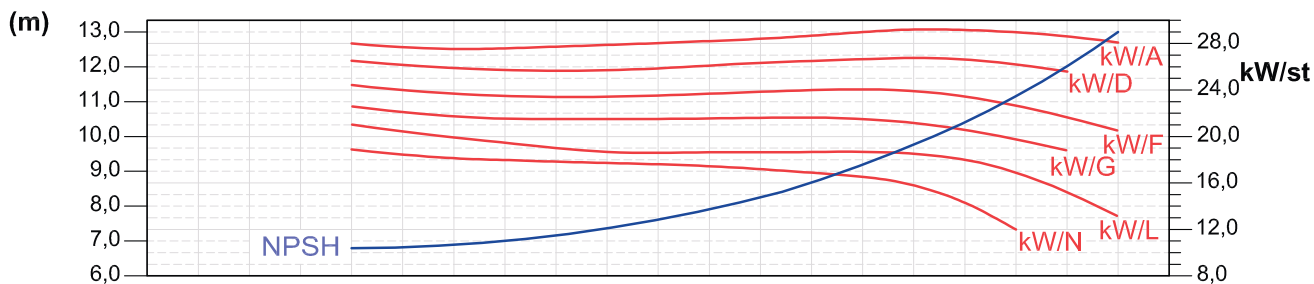

Tolleranze secondo EN ISO 9906 app.A Gr.2 - Tolerances according to EN ISO 9906 anx.A Gr.2 - Tolérances conformes EN ISO 9906 ann.A Gr.2