

A5

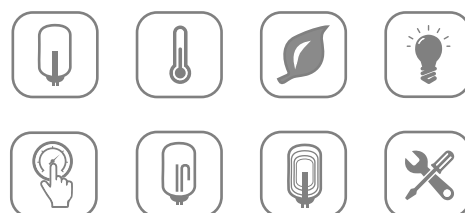

Models	H mm	L mm	P mm	
A5 SP	340	250	245	oversink
A5 ST	340	250	245	undersink

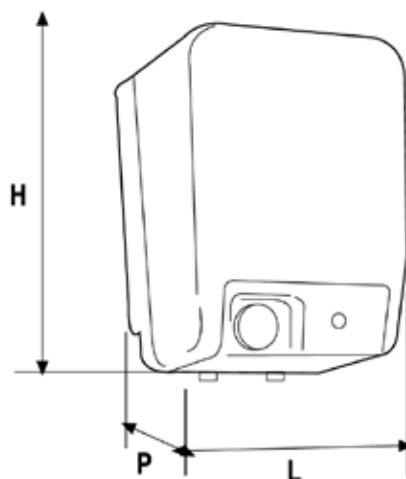
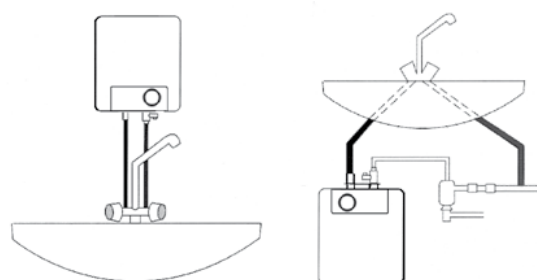

Models	Thermal Dispersion 65° (Kwh/24h)	Power Watts*	Voltage Volts	Heating Time dt 50°C	Max Temperature C°	Max Pressure (bar)	Humidity Protection	Class Insul.	Profile	Energy Class
A5 SP	0,38	1500	230	16'	50	8	IPX4	I	XXS	B
A5 ST	0,38	1500	230	16'	50	8	IPX4	I	XXS	B