

## Electronic control panels

# DUAL MOTOR RANGE 0,5÷20HP

**Direct starting electronic control panel 2 motors for pressure booster**

- Single-phase version equipped with power relay for inductive loads (up to 31A)
- Motherboard protection



### GENERAL SPECIFICATIONS

- Operating voltage 230Vac +15/-20% 50/60Hz (SA623.xx)
- Operating voltage 400Vac +15/-20% 50/60Hz (SA626.xx)
- General disconnecting switch with door lock
- N°2 buttons for automatic -0- manual operation
- Maximum current trimmer for each motor
- "POWER" Led light (supply mains)
- N°2 running Led lights
- N°2 motors' overload Led lights
- N°2 motors' status Led lights
- "ALTERNANCE" Led light (pressure switches status)
- "LEVEL" Led light (level status)
- Auxiliary circuit protection fuse
- Motors' protection fuse
- N°2 contactors (SA626.xx)
- External thermoplastic box
- Cable glands
- Protection degree IP65
- Operating temperature -5/+50°C
- Relative humidity 60% at 50°C (not condensed)

### INPUTS / OUTPUTS

- Very low voltage input for start pressure
- Very low voltage input for emergency pressure
- N°2 very low voltage inputs for float switches or probes

### ADVANTAGES

- Configuration via Dip switch
- Deactivable alternance of the 2 motors
- 3s delay between the starting of the 2 motors
- Automating switching in case of motor failure
- Operation with pressure switches, float switches and probes
- Dry running with level control

### PROTECTIONS

- Maximum current protection for each motor with alarm
- Lack and sequence of phases protection with automatic reset and alarm
- Deactivable minimum and maximum voltage protection with automatic reset and alarm

**SINGLE-PHASE 230Vac +15/-20% 50/60Hz**

CODE	TYPE	POWER		OPERATING CURRENT [A]	DIMENSIONS mm			WEIGHT Kg	BOX
		kW	Hp		A-H	L-W	P-D		
SA623.00	DUAL MOTOR 230	0,37÷2,2	0,5÷3	2x(2÷18)	285	245	140	2,3	03

**THREE-PHASE 400Vac +15/-20% 50/60Hz**

CODE	TYPE	POWER		OPERATING CURRENT [A]	DIMENSIONS mm			WEIGHT Kg	BOX
		kW	Hp		A-H	L-W	P-D		
SA626.02L	DUAL MOTOR 400 10	0,37÷7,5	0,5÷10	2x(0,5÷16)	345	285	165	3,7	04
SA626.03L	DUAL MOTOR 400 15	2,2÷11	3÷15	2x(4÷25)	380	300	150	5,2	05
SA626.04L	DUAL MOTOR 400 20	7,5÷15	10÷20	2x(16÷32)	460	380	150	6,5	07

**OPTIONALS**

CODE	TYPE
OP100.01	3 level probes kit
OP100.05	Wired single-phase surge arrester type 2
OP100.05/1	Wired three-phase surge arrester type 2
OP00.10	Couple of brackets for collar (reference BOX 03-04)

For more optionals see page 78

**SPARE PARTS**

CODE	TYPE
AC100.21/1/30	Scheda elettronica Led 2 pompe con cavo flat 16pin 30cm
SD623.20/1	Scheda elettronica DUAL MOTOR monofase
SD626.20/1	Scheda elettronica DUAL MOTOR trifase 20A
SD626.30-40/1	Scheda elettronica DUAL MOTOR trifase 30-40A

**PRESSURE BOOSTER**

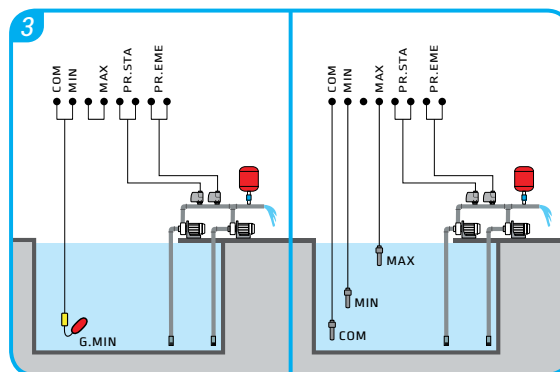

**COMPONENTS KEY**

- Float switch for clean water**
- Pressure switch**
- Level probes**

The addition of some optionals can imply changes on the size of the control panel. For further details please contact our technical/commercial department.