

Electromechanical control panels

EVO 2 MULTI RANGE 0,5÷20HP

Direct starting electromechanical control panel 2 motors for pressure booster and sewage

- Multi-application control panel
- Motors alternance
- 3s delay between the starting of the 2 motors
- Protection fuse for each motor



GENERAL SPECIFICATIONS

- Operating voltage 230Vac $\pm 10\%$ 50/60Hz (SA653.xx)
- Operating voltage 400Vac $\pm 10\%$ 50/60Hz (SA663.xx)
- General disconnecting switch with door lock
- N°2 selector switches for automatic -0- manual operation (stable)
- Mains supply Led light
- N°2 running Led lights
- N°2 overload Led lights
- Auxiliary circuit protection fuse
- Transformer for auxiliary circuit
- Protection fuse for each motor
- N°2 contactors
- N°2 thermal relays (internal reset)
- Connection terminal board
- External thermoplastic box
- Cable glands
- Protection degree IP65
- Operating temperature -5/+40°C

ADVANTAGES

- Configuration via Dip switch
- Alternance of the 2 motors
- 3s delay between the starting of the 2 motors

INPUTS / OUTPUTS

- N°2 very low voltage input for pressure switch or float switches (minimum/maximum motor 1 level)
- N°2 very low voltage input for pressure switch or float switches (minimum/maximum motor 2 level)

PROTECTIONS

- Maximum current protection for each motor with alarm

SINGLE-PHASE 230Vac ±10% 50/60Hz

CODE	TYPE	POWER		OPERATING CURRENT [A]	DIMENSIONS mm			WEIGHT Kg	BOX
		kW	Hp		A-H	L-W	P-D		
SA653.00L	EVO 2 MULTI 230 0,5	0,37	0,5	2x(2,5÷4)	380	300	150	6,5	05
SA653.01L	EVO 2 MULTI 230 0,75	0,55	0,75	2x(4÷6,5)	380	300	150	6,5	05
SA653.02L	EVO 2 MULTI 230 1	0,75	1	2x(6,3÷10)	380	300	150	6,5	05
SA653.03L	EVO 2 MULTI 230 1,5	1,1	1,5	2x(6,3÷10)	380	300	150	6,5	05
SA653.04L	EVO 2 MULTI 230 2	1,5	2	2x(9÷14)	380	300	150	6,5	05
SA653.05L	EVO 2 MULTI 230 3	2,2	3	2x(13÷18)	380	300	150	6,5	05

THREE-PHASE 400Vac ±10% 50/60Hz

CODE	TYPE	POWER		OPERATING CURRENT [A]	DIMENSIONS mm			WEIGHT Kg	BOX
		kW	Hp		A-H	L-W	P-D		
SA663.00L	EVO 2 MULTI 400 0,5	0,37	0,5	2x(1,1÷1,6)	380	300	150	6,5	05
SA663.01/02L	EVO 2 MULTI 400 1	0,55÷0,75	0,75÷1	2x(1,6÷2,5)	380	300	150	6,5	05
SA663.03L	EVO 2 MULTI 400 1,5	1,1	1,5	2x(2,5÷4)	380	300	150	6,5	05
SA663.04L	EVO 2 MULTI 400 2	1,5	2	2x(4÷6,5)	380	300	150	6,5	05
SA663.06/07L	EVO 2 MULTI 400 4	2,2÷3	3÷4	2x(6,3÷10)	380	300	150	6,5	05
SA663.09L	EVO 2 MULTI 400 5,5	4	5,5	2x(9÷14)	380	300	150	6,5	05
SA663.10L	EVO 2 MULTI 400 7,5	5,5	7,5	2x(13÷18)	380	300	150	6,5	05
SA663.11L	EVO 2 MULTI 400 10	7,5	10	2x(17÷23)	380	300	150	6,9	05
SA663.12L	EVO 2 MULTI 400 12,5	9,2	12,5	2x(20÷25)	380	300	150	6,9	05
SA663.13/14L	EVO 2 MULTI 400 17,5	11÷13	15÷17,5	2x(24÷32)	460	380	150	7,2	07
SA663.15L	EVO 2 MULTI 400 20	15	20	2x(32÷38)	460	380	150	7,4	07

OPTIONALS

CODE	TYPE
OP100.02/0	Automatic -0- manual selector switch (from stable to unstable)
OP100.02/1	Wired start-stop button
OP100.04/4	Wired lack, sequence and asymmetry of phases relay
OP100.04/5	Wired lack, sequence and asymmetry of phases relay, minimum and maximum voltage
OP100.05	Wired single-phase surge arrester type 2
OP100.05/1	Wired three-phase surge arrester type 2
OP100.15/024	Wired hour counter 24Vac 48x48
OP100.16/1	Wired analog daily timer 72x72 without reserve
OP100.16/2	Wired analog daily timer 72x72 with reserve
OP100.19/4	Wired module GSM 4 inputs/4 outputs
OP100.09/2	Wired lithium battery 3,7Vdc 600mAh
OP210.01	Wired very low voltage input for motor klixon
OP200.01	Alarm output 24Vac and pure contact
OP100.13/1	Wired siren shut-off button
OP100.13/1/24	Wired siren 24Vac/dc
OP100.13/2/24L	Wired flashing Led lamp 24Vac
SS100.01	Visual and acoustic alarm indicator (BASIC ALARM VA 024) see page 20
SS101.01	Visual and acoustic alarm indicator with buffer battery (TOP ALARM VAB 230) see page 19

For more optionals see page 126

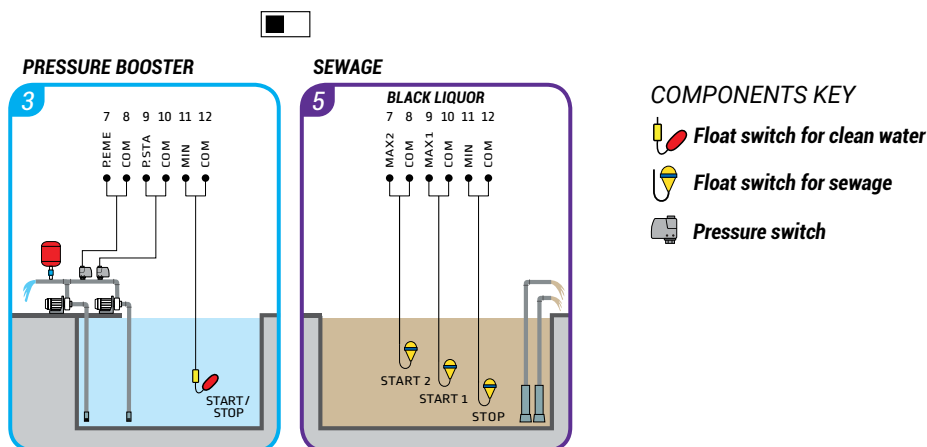

The addition of some optionals can imply changes on the size of the control panel. For further details please contact our technical/commercial department.